

**CORNELL PUMP COMPANY****500 - 1600 GPM   Model 4NHTB   140 - 450 Feet TDH****STANDARD SPECIFICATION**

**Discharge** - 4 inch discharge

**Suction** - 5 inch suction

**Impeller** - Enclosed, threaded, 2 vane: handles  
3" solids

**Volute** - Right and left hand tangential discharge,  
in twelve positions

**Mechanical Seal or Traditional Packing** - Single  
type 2 tungsten silicon mechanical seal: Cycloseal®  
design, Run-dry available

**Materials of Construction**

- Cast iron casing, cast iron impeller
- Other materials available

**MOUNTING OPTIONS**

• **Frame Mount**

- Cornell F18
- Cornell F18DB

• **Engine Bracket**

- Cornell EM18 (SAE 1, 2, 3, 4)
- Cornell EM18DB (SAE 1, 2, 3, 4)

• **Oil Filled Bearing Frame**

- Optional

• **Redi-Prime Self Priming System**

- Optional

**AVAILABILITY**

• **Quick Ship**

- Finished Product Regularly Stocked  
(48 Hours)

• **Preferred Pump**

- Finished Components Regularly Stocked  
(10 business days)

• **Specialty Pump**

- Cornell Pump Company will design and  
manufacture a variation of this pump  
specifically designed for your application

**FEATURES & BENEFITS**

• **Cornell's Tradition of Excellence:**

- **Highest quality products**
- **Experience**
  - Over 50 years in the centrifugal pump business
- **Optimum Hydraulics**
  - In house engineering staff and test lab facilities
- **Strong Local Dealer Support**
  - Our agricultural products are sold only through  
authorized dealerships
  - Dealerships provide full service to customers from  
sales to replacement parts
  - Dealers maintain and improve their knowledge at  
educational activities like Cornell's "Pump School"

• **Exceptional Design:**

- **Efficiency**
  - Effectively converts energy into fluid flow and  
pressure
- **Long Product Life**
  - Thick walled castings
  - Heavy duty shafts
  - 20,000 hour bearings
  - Replaceable wear rings and shaft sleeves

# PERFORMANCE CURVES

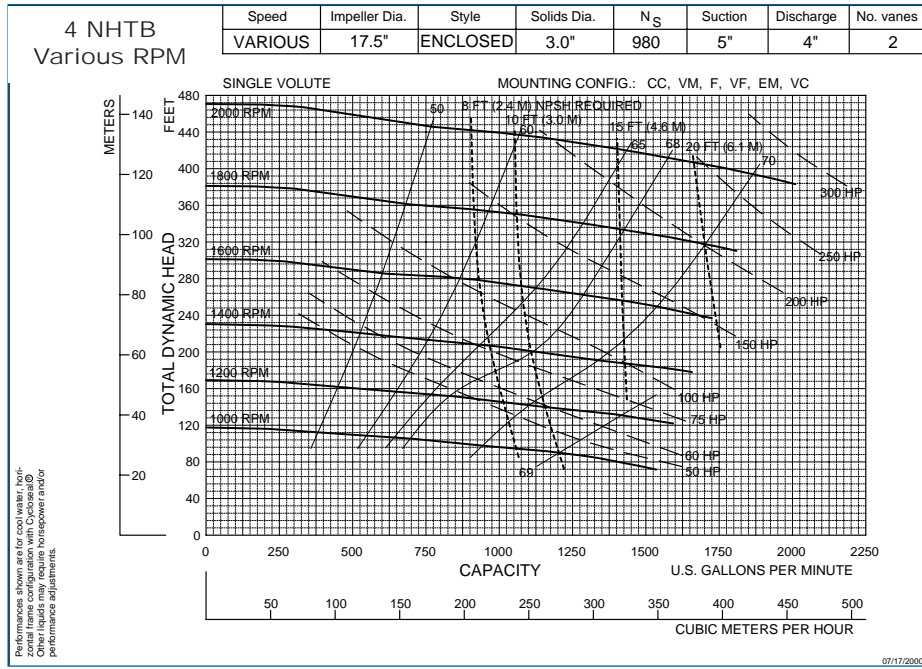

**Note:**  
Curves also available in 1800 and 1200 RPM

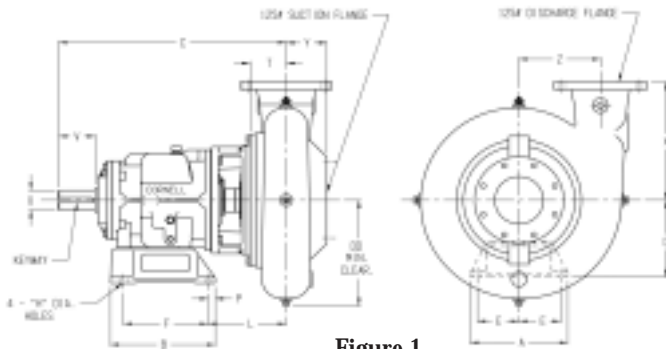

Figure 1

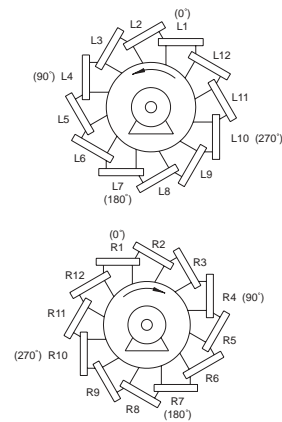

Figure 2

## PUMP DIMENSIONS

MOUNT	Fig.	A	AR	B	C	CP	D	DA	DD	E	F	H	L	LP	P	R	T	U	V	X	Y	Z	KEYWAY
F18	1	12	-	12.88	28.44	-	10.5	-	13.12	5.12	10.38	0.81	10.09	-	0.88	-	4.41	2.5	4.5	15.5	5	10.25	.62 X .31
EM18	2	-	6	-	28.44	31.44	-	13.12	13.12	-	-	-	-	-	-	19.38	4.41	2.5	-	15.5	5	10.25	.62 X .31

**Cornell Pump Company**

P.O. Box 6334 • Portland, Oregon 97228-6334

Web: [www.cornellpump.com](http://www.cornellpump.com) • Phone (503) 653-0330 • Fax (503) 653-0338

**ISO9001:2000** CERTIFIED