



CORNELL PUMP COMPANY

Model 8H-EM Redi-Prime®

PUMP SPECIFICATIONS

- **Size:** 8H - 8" discharge x 10" suction with 125# cast iron flanges.
- **Casing:** Cast Iron.
- **Impeller:** Enclosed - 6 vane. Handles 1.25" diameter solids.
- **Wear Rings:** Replaceable. (Double wear rings available).
- **Seal:** Cornell's patented Cycloseal® design with Run-Dry oil lubrication system. John Crane T-2 single mechanical seal with Viton® elastomers, stainless steel hardware and tungsten- vs. silicon-carbide seal faces for abrasion resistance.
- **Check Valve:** SwingFlex® Val-Matic®.
- **Shaft Sleeve:** Heat treated 416 stainless steel.
- **Bearings:** Heavy duty, grease lubricated, deep groove ball bearings, with a minimum of 50,000 hours bearing life.
- **Hardware:** Stainless steel float linkage. A positive seating vacuum priming valve prevents water carry-over to the vacuum, pump or atmosphere.
- **Vacuum Pump** - 50 SCFM Maximum.

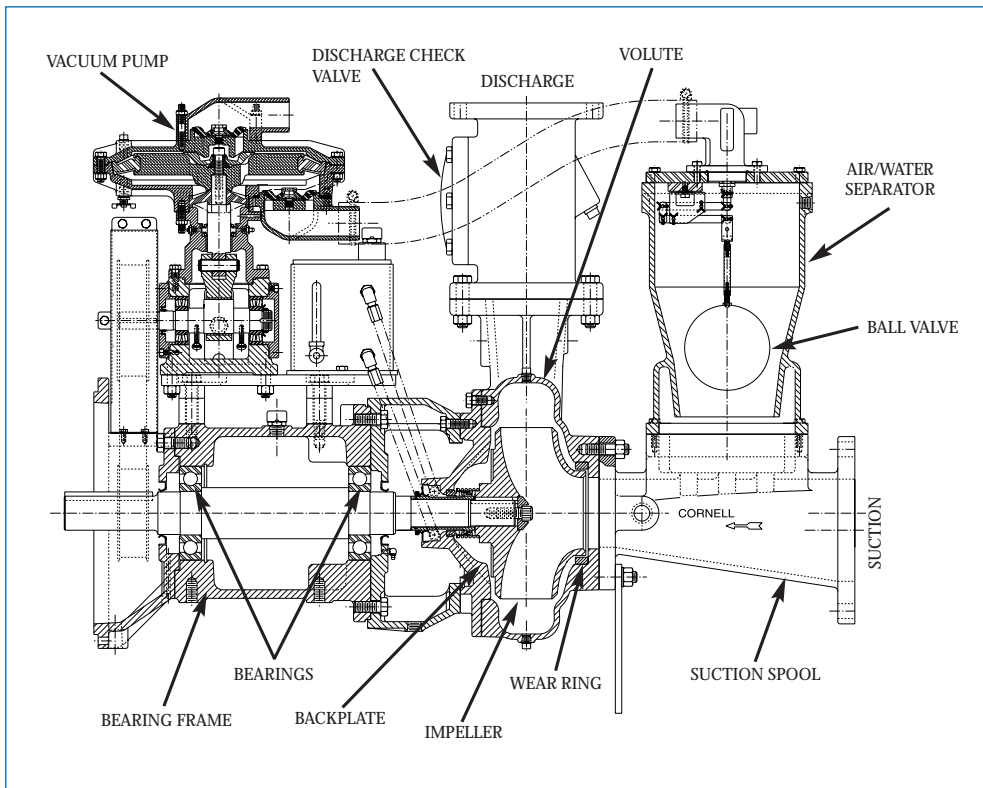

PUMP DIMENSIONS

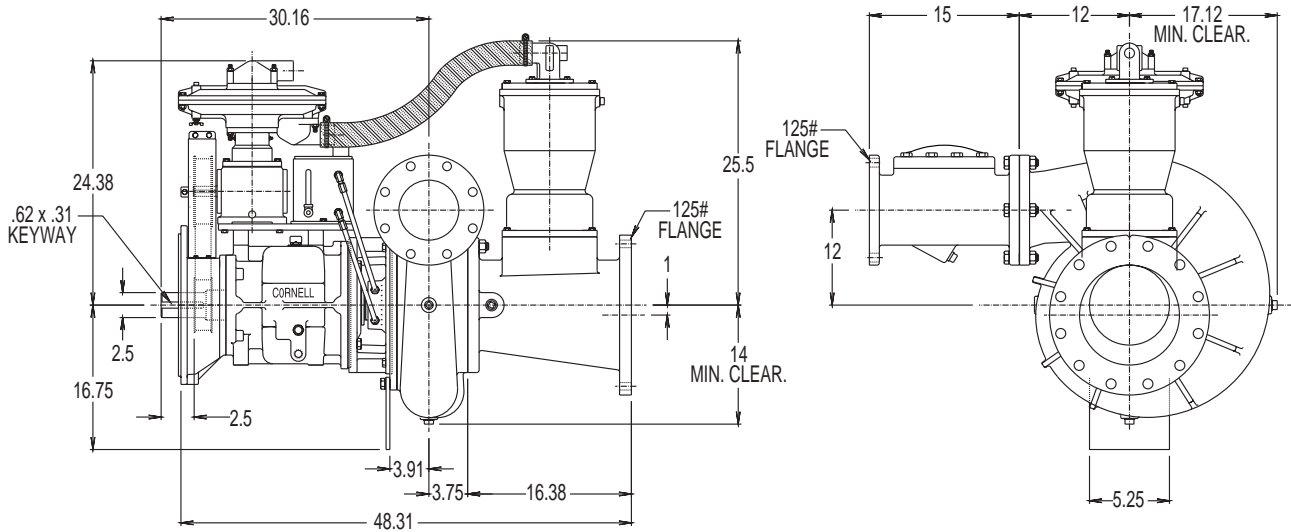

- NOTES:**
1. Flange connection dimension can vary $\pm .12$ inch.
 2. Do not use for construction unless certified.

PERFORMANCE CURVES

Feet x .305 = Meters
 Inches x 25.4 = Millimeters
 GPM x .227 = Cubic Meters/Hour
 GPM x 3.785 = Liters/Minute
 HP x .746 = KW

Speed	Impeller Dia.	Style	Solids Dia.	N _S	Suction	Discharge	No. vanes
VARIOUS	15.22"	ENCLOSED	1.25"	2081	10"	8"	6

DOUBLE VOLUTE

MOUNTING CONFIG.: F, EM

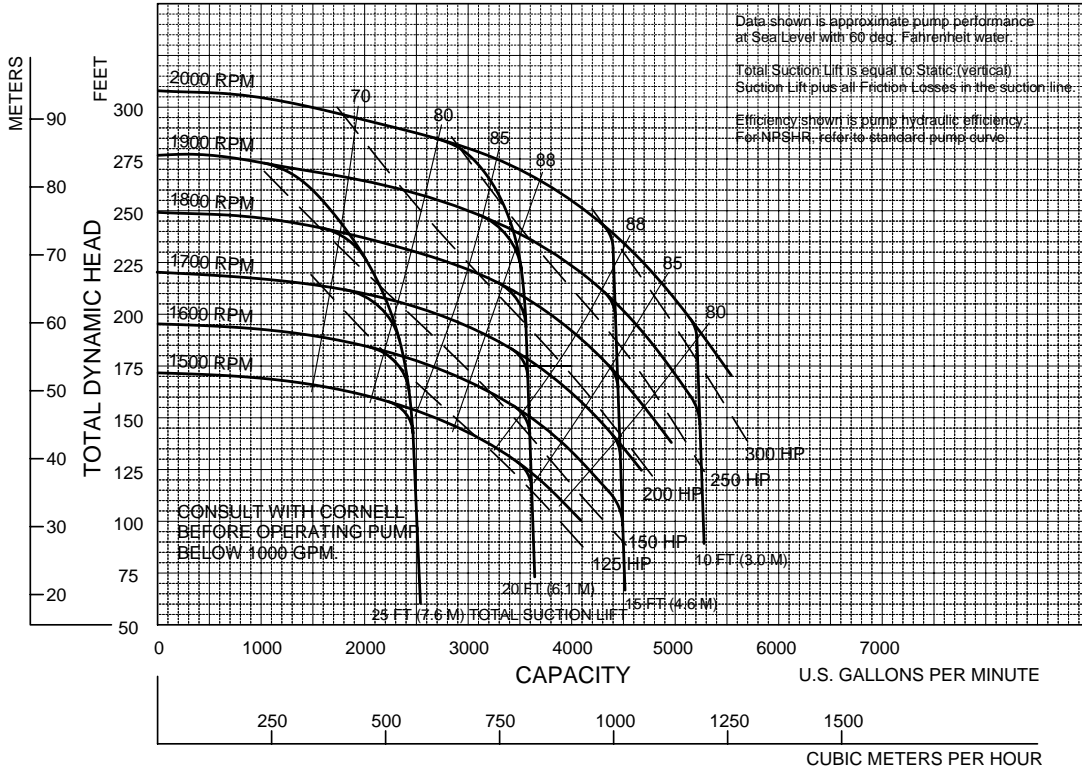

Performances shown are for cool water, frame mounted configuration with Cyclo Seal®. Other liquids or mounting configurations may require performance adjustments.
 Add 1.5 HP for belt driven diaphragm vacuum pump. Performance curve does not include discharge check valve losses.

CONSULT WITH CORNELL BEFORE OPERATING PUMP BELOW 1000 GPM.
 20 FT. (6.1 M) TOTAL SUCTION LIFT 15 FT. (4.6 M)

Cornell Pump Company

P.O. Box 6334 • Portland, Oregon 97228-6334

Web: www.cornellpump.com • Phone (503) 653-0330 • Fax (503) 653-0338

ISO9001: 2000 CERTIFIED